

SERIE 228

Digitaler Einbaumessschieber mit zylindrischer Stange

- Mechanik aus rostfreiem Stahl, gehärtet und geschliffen
- Preset Funktion
- Wechsel mm / inch
- Nulleinstellung
- Patentiertes Messsystem
- Verstellgeschwindigkeit 2 m / s
- Simplex Übertragung
- Autonomie zwischen 3300 und 4400 h
- Externe Stromversorgungsmöglichkeit
- LCD Anzeige, Ziffernhöhe 6 mm

Digital scale with cylindrical beam

- Frame in stainless steel, hardened and grinded
- Preset facilities
- mm / inch selection
- Zero setting
- Patented measuring system
- Operational speed: 2 m / sec
- Simplex transmission
- Self-contained use: 3300 to 4400 h
- External power supply possibility
- Display LCD, height of digits 6 mm

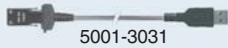
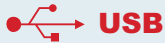

5001-3031



5001-2001

Bestell-Nr. Order no.	Messbereich Measuring range	Ausführung Execution	Fehlergrenzen Max. error fe	Wiederholbarkeit Repeatability	Auflösung Resolution	Abmessungen Sizes (mm)
4071-3002	300 mm	H	30 µm	10 µm	0.01 mm	
4071-3004	600 mm	H	40 µm	10 µm	0.01 mm	L = C + 2.5% + 120
4071-3006	800 mm	H	50 µm	10 µm	0.01 mm	A = L - 16
4071-3008	1000 mm	H	50 µm	10 µm	0.01 mm	
4071-3502	300 mm	V	30 µm	10 µm	0.01 mm	
4071-3504	600 mm	V	40 µm	10 µm	0.01 mm	L = C + 2.5% + 120
4071-3506	800 mm	V	50 µm	10 µm	0.01 mm	A = L - 16
4071-3508	1000 mm	V	50 µm	10 µm	0.01 mm	

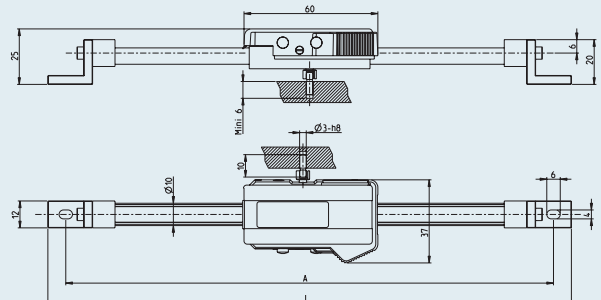
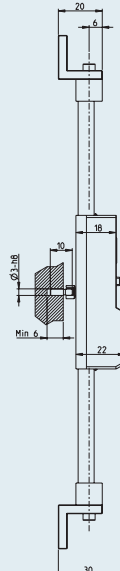
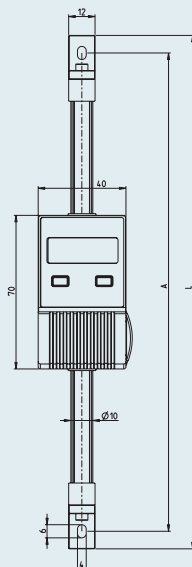

Mitnehmvorrichtung und Zubehör,
siehe Seite C 17
Drive type fastening and accessories,
see page C 17