

Elektr. Messeinheiten XT3DU / XT3PG

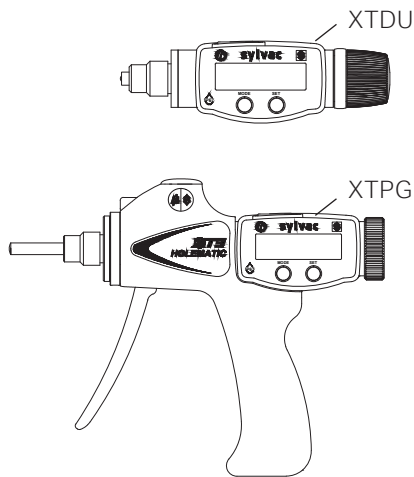

Bestell-Nr.	Typ	Bestell-Nr. (Bluetooth®)	Typ (Bluetooth®)	Messbereich Ø mm	Gewinde
2802-1110	XT3DU2	2802-1210	XT3DU2 BT	2 – 6	1/4" x 40 TPI
2802-1112	XT3DU6	2802-1212	XT3DU6 BT	6 – 10	M5 x 0.5
2802-1114	XT3DU10	2802-1214	XT3DU10 BT	10 – 20	5/16" x 40 TPI
2802-1116	XT3DU20	2802-1216	XT3DU20 BT	20 – 50	5/8" x 24 TPI
2802-1118	XT3DU50	2802-1218	XT3DU50 BT	50 – 100	5/8" x 24 TPI
2802-1120	XT3DU100	2802-1220	XT3DU100 BT	100 – 200	5/8" x 24 TPI
2802-1124	XT3DU200	2802-1224	XT3DU200 BT	200 – 300	5/8" x 24 TPI
2802-2110	XT3PG1	2802-2210	XT3PG1 BT	2 – 6	1/4" x 40 TPI
2802-2112	XT3PG2	2802-2212	XT3PG2 BT	6 – 20	5/16" x 40 TPI
2802-2116	XT3PG3	2802-2216	XT3PG3 BT	20 – 100	5/8" x 24 TPI
2802-2128	XT3PG4	2802-2228	XT3PG4 BT	100 – 300	5/8" x 24 TPI

Messköpfe XTHD

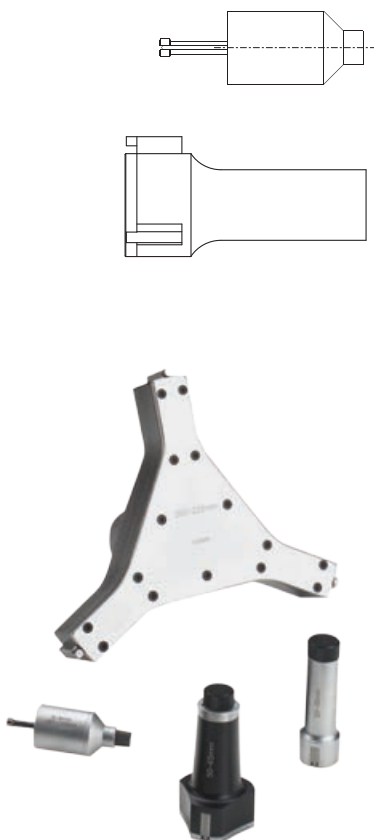

Bestell-Nr.	Typ	Messbereich Ø mm	Ausführung
2802-1010	XTHD1	2 – 2.5	2-Punkt / ST
2802-1012	XTHD2	2.5 – 3	2-Punkt / ST
2802-1014	XTHD3	3 – 4	2-Punkt / ST
2802-1016	XTHD4	4 – 5	2-Punkt / ST
2802-1018	XTHD5	5 – 6	2-Punkt / ST
2802-1020	XTHD6	6 – 8	3-Punkt / ST
2802-1022	XTHD8	8 – 10	3-Punkt / ST
2802-1024	XTHD10	10 – 12.5	3-Punkt / ST
2802-1026	XTHD12.5	12.5 – 16	3-Punkt / TC
2802-1028	XTHD16	16 – 20	3-Punkt / TC
2802-1030	XTHD20	20 – 25	3-Punkt / TC
2802-1032	XTHD25	25 – 35	3-Punkt / TC
2802-1034	XTHD35	35 – 50	3-Punkt / TC
2802-1036	XTHD50	50 – 65	3-Punkt / TC
2802-1038	XTHD65	65 – 80	3-Punkt / TC
2802-1040	XTHD80	80 – 100	3-Punkt / TC
2802-1042	XTHD100	100 – 125	3-Punkt / TC
2802-1044	XTHD125	125 – 150	3-Punkt / TC
2802-1046	XTHD150	150 – 175	3-Punkt / TC
2802-1048	XTHD175	175 – 200	3-Punkt / TC
2802-1050	XTHD200	200 – 225	3-Punkt / TC
2802-1052	XTHD225	225 – 250	3-Punkt / TC
2802-1054	XTHD250	250 – 275	3-Punkt / TC
2802-1056	XTHD275	275 – 300	3-Punkt / TC
2802-1058*	XTHD300	300 – 325	3-Punkt / TC

* Inklusive Messeinsätze 2802-3110

ST = Stahl TC = Hartmetall

Einstellringe

XTR nach DIN 2250C

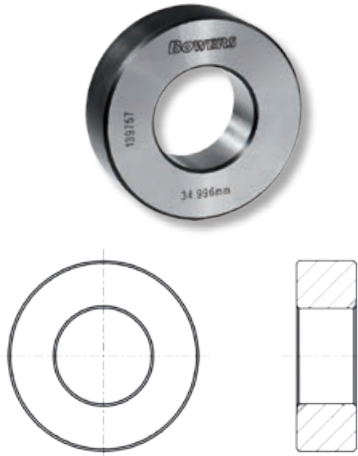

Bestell-Nr.	Typ	Durchmesser mm
6101-2002	XTR2.5	2.5
6101-1004	XTR4	4
6101-1005	XTR5	5
6101-1008	XTR8	8
6101-2012	XTR12.5	12.5
6101-1020	XTR20	20
6101-1035	XTR35	35
6101-1065	XTR65	65
6101-1080	XTR80	80
6101-1125	XTR125	125
6101-1175	XTR175	175
6101-1225	XTR225	225
6101-1275	XTR275	275

Verlängerungen



Bestell-Nr.	Typ	Durchmesser mm	Länge mm
2802-5020	SX200	6 – 10	63
2802-5024	SX400	10 – 12.5	76
2802-5026	SX500	12.5 – 20	100
2802-5030	SX1	20 – 50	150
2802-5036	SX4	50 – 300	150

Weiteres Zubehör

Bestell-Nr.	Beschreibung	Messbereich Ø mm
2802-6001	Stativ	
2802-6002	Tiefenanschlag	2 – 6

Spezialeinsätze für Innenmessgeräte auf Anfrage

